



LASE 2004 Presentation
Conference 5332 Solid State Lasers XIII: Technology and Devices
Presentation 5332-14



Diode-Pumped Er,Yb:glass Micro-Laser

C. Ward Trussell

Vernon King

Alan D. Hays

Night Vision & Electronic Sensors Directorate, US Army RDECOM

Scott J. Hamlin

MegaWatt Lasers, Inc.

PO Box 24190

Hilton Head Island, SC 29925-4190

scott.hamlin@megawattlasers.com

MegaWatt Lasers



Eyesafe Laser Rangefinder Transmitters Requirements



- Lightweight
- Small
- Low cost
- Operation over temperature
- Battery operated, low power consumption
- Single shot up to 10 pulses/sec.
- Energy : $\sim 100 \mu\text{J}$
- Pulse width: $< 5 \text{ nsec}$

MegaWatt Lasers

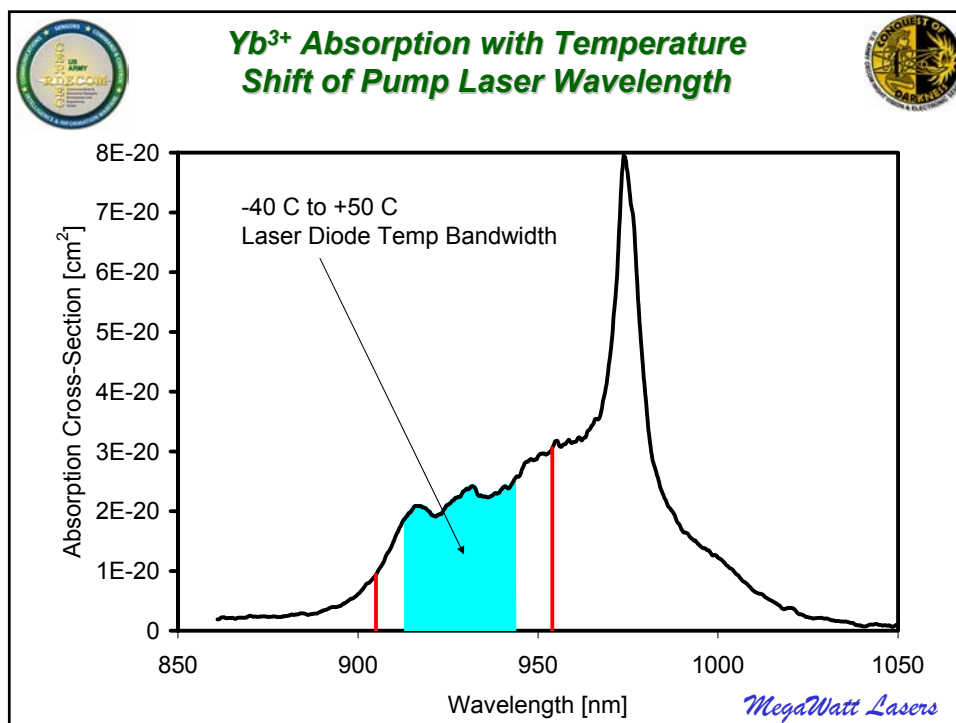
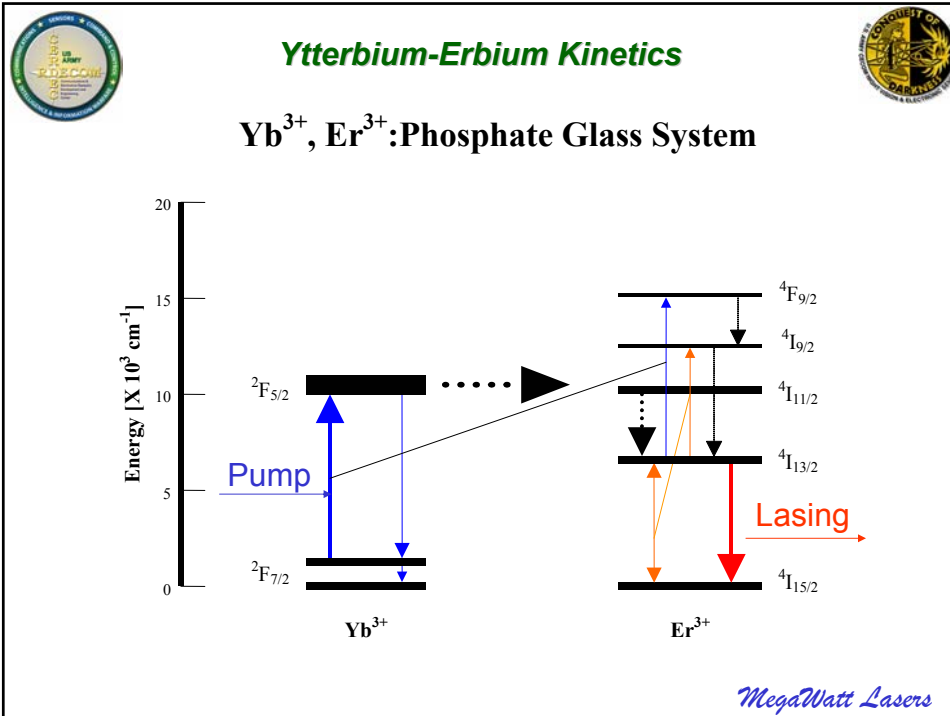



Micro Eyesafe Solid State Laser Diode-Pumped Er,Yb:glass Approach

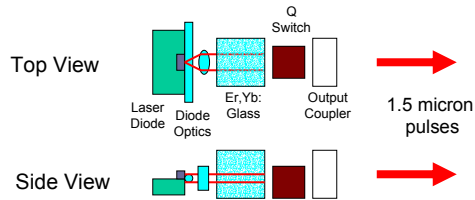

End Pumped Laser

- Good pump/laser mode overlap
- Long pump absorption length
- Wide Temp range for laser diode
- High Efficiency

Er,Yb:glass

- Direct 1.5 micron output (no OPO)
- Long fluorescence Lifetime (20x Nd:YAG)
- Single stripe pump laser diode
- Low cost material

Performance Results:

Single laser diode: 3 watts at 925nm, 3 milliseconds pump time, 9 mJ pump energy
 Energy Output at 1.54 microns: 90 to 120 micro-joules, 2 ns pulse, 10 Hz.
 Peak Power: ~ 50 kW
 Electrical input: 20 mJ/pulse at 10 Hz = 200 mW

MegaWatt Lasers



Diode Pump Optics Design using ZEMAX

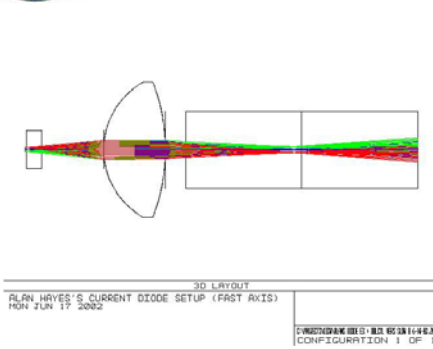

Unit #2 Design

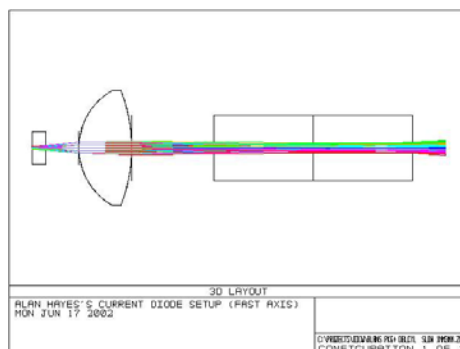

New design with more
uniform pump beam

ZEMAX model by Jerry Franck (NVESD)

MegaWatt Lasers



Diode Pumped Er:Yb:glass Micro-laser Packaged in TO3 can

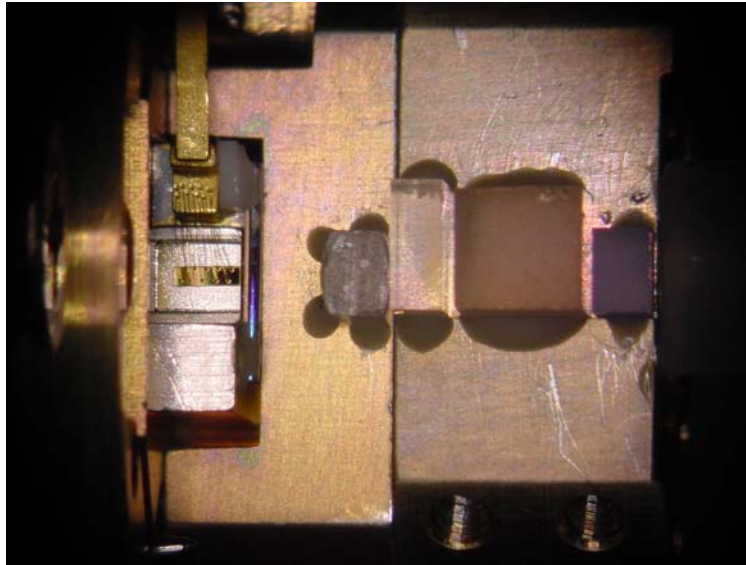

MegaWatt Lasers



Er,Yb:glass micro-laser packaging design by Alan Hays (NVEDS)



MegaWatt Lasers



Assembly and Test Facility



MegaWatt Lasers



Diode Pumped Er:Yb:glass Micro-laser Recent results with TO3 package

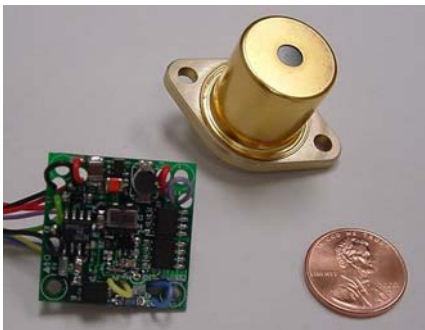

Micro-laser in TO3 package and Diode drive circuit for use with L123 Battery.

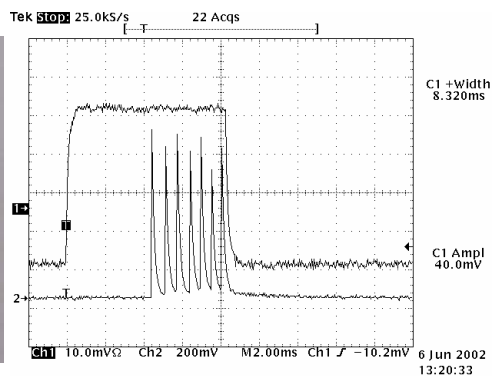

Oscilloscope traces showing diode pump current for 8 milliseconds and 7 q-switched pulses with approximately 80 micro-joules/pulse. Pulses are stretched for display. Actual pulse width is 2 ns.

MegaWatt Lasers



Eye-Safe Laser Output Pulse

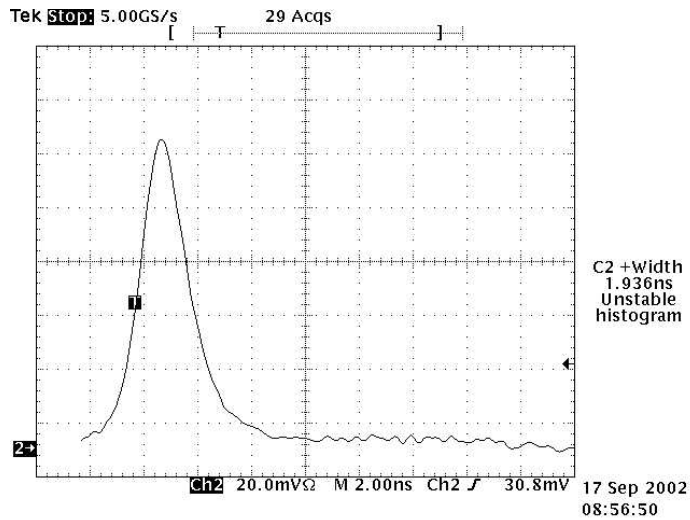

MegaWatt Lasers



Beam Quality

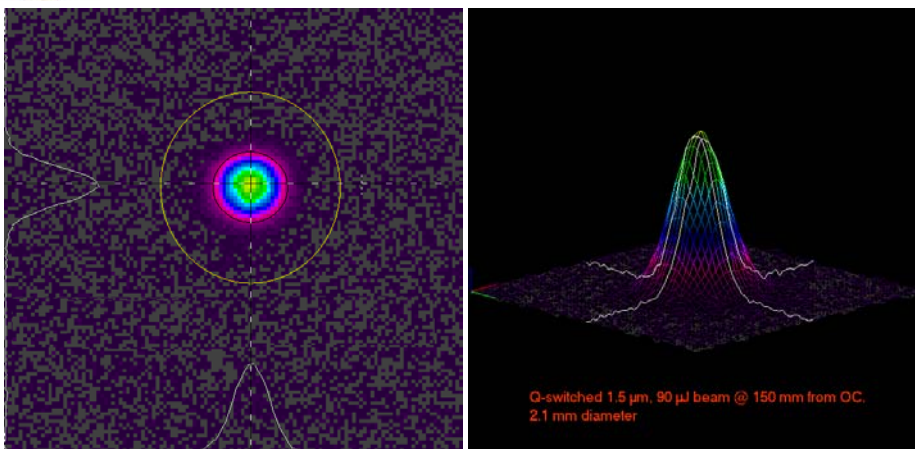

Beam Quality < 2.6 mm-mrad

MegaWatt Lasers



Time to Q-switch vs. laser diode power NV01 glass

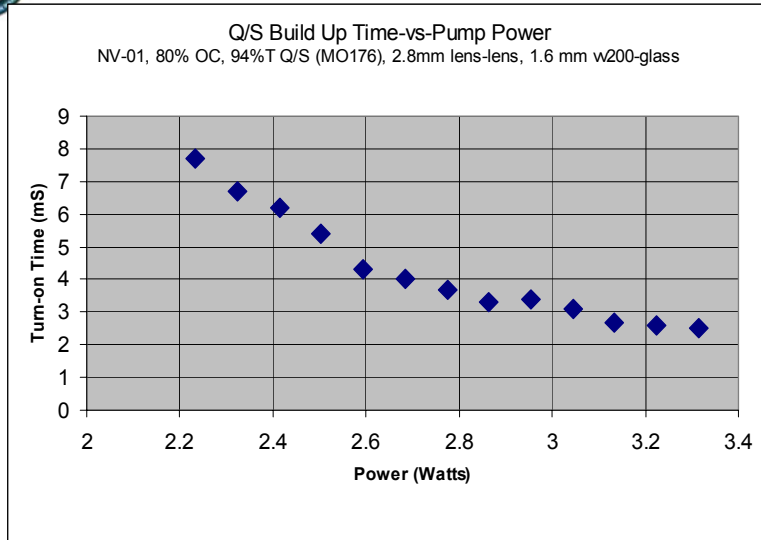

MegaWatt Lasers



Eye-Safe Laser Environmental Test

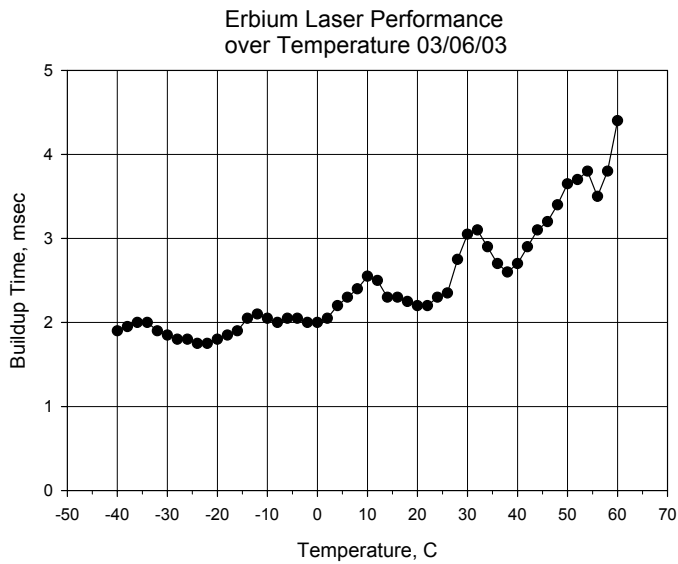

MegaWatt Lasers



Pulse Timing Jitter

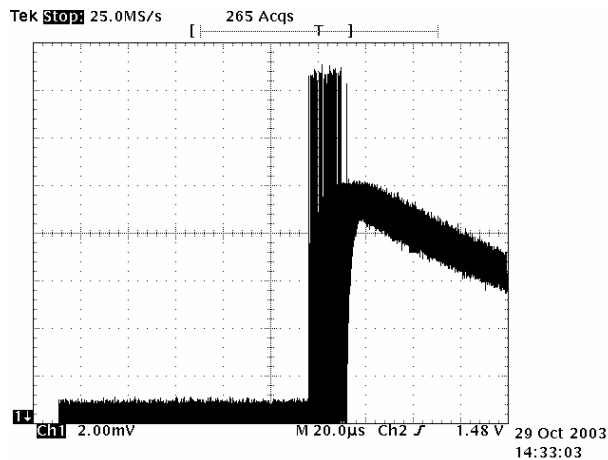

MegaWatt Lasers



Intended Application: OICW / Land Warrior

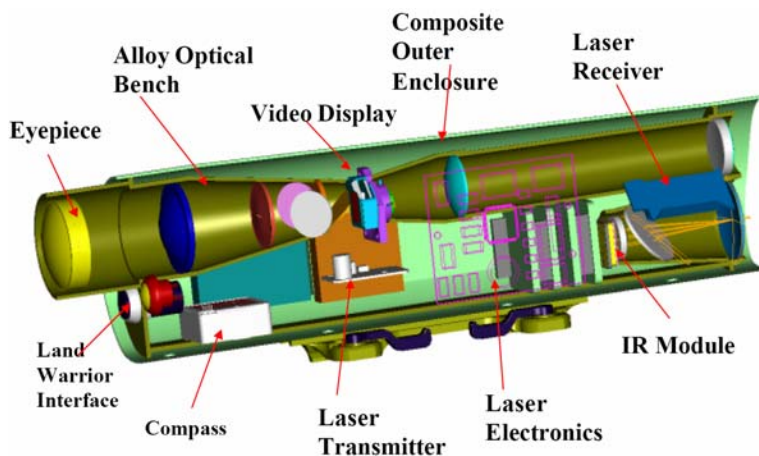

BRASHEAR LP

MegaWatt Lasers

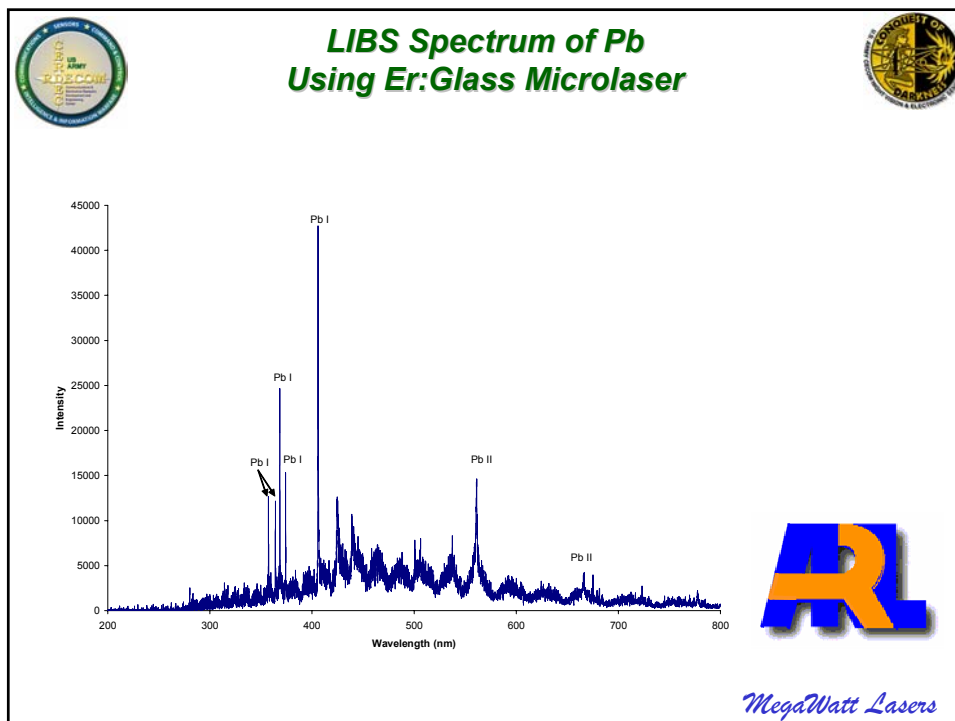
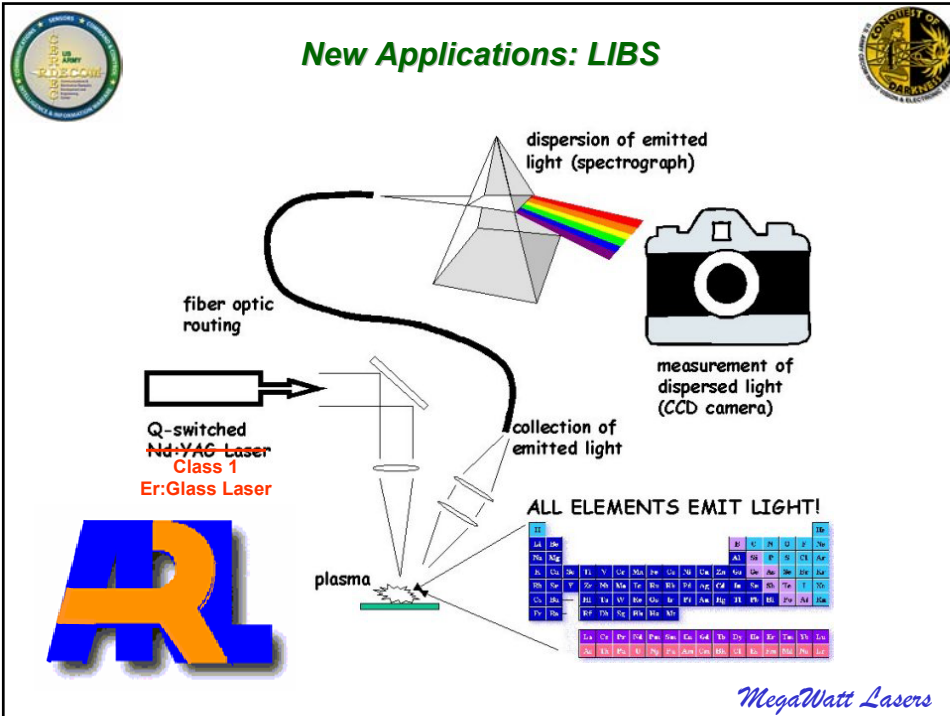



Butterfly Package

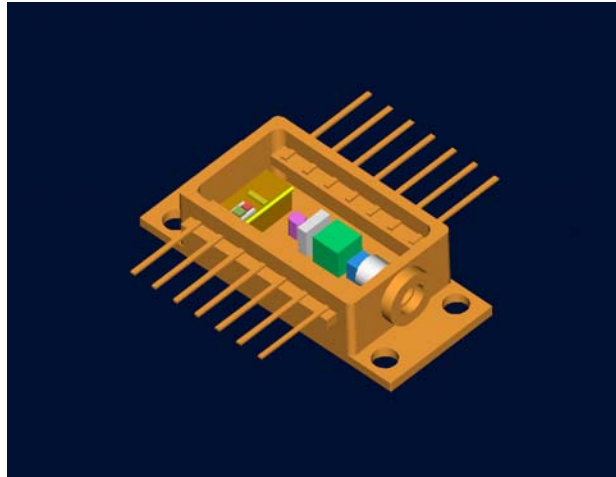

MegaWatt Lasers



Butterfly Package Pinout

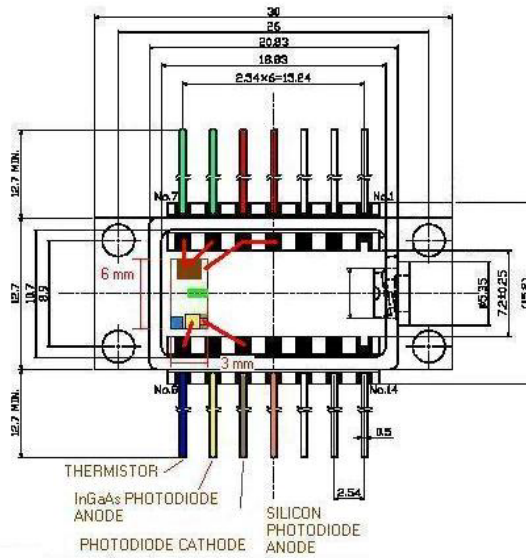

MegaWatt Lasers



PRO-E Model of NVL Rangefinder

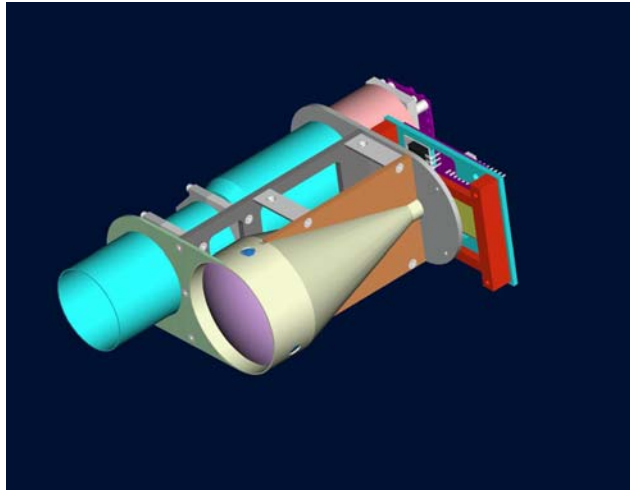

Early tests using a 30 mm aperture saw ranges in Excess of 2 km.

MegaWatt Lasers



Diode Pumped Er,Yb:glass Micro-Laser Summary



- Lightweight Eyesafe Micro-Laser developed for Rangefinder Applications: 12 gm
- Wavelength: 1.54 μm for eyesafety
- Energy: 80 to 120 μJ
- Pulse Width: 2.0 nsec
- Peak Power: ~ 50 kW
- PRF: 1 to 20 Hz
- Beam Quality < 2.4 mm-mrad, 1.2 x D.L.
- Tested to 4×10^6 with No Degradation @ 60 $^{\circ}\text{C}$
- Low cost projected

MegaWatt Lasers